

Serial Interface Adapter for TC500 A/D Converter Family

Features

- Converts TC500/TC500A/TC510/TC514 to Serial Operation
- Programmable Conversion Rate and Resolution for Maximum Flexibility
- Supports up to 17-Bits of Accuracy Plus Polarity Bit
- Low Power Operation: Typically 7.5mΩ
- 14-Pin PDIP or 16-Pin SOIC Packages
- Polled or Interrupt Mode Operation

Applications

- Computer Peripheral Interface
- Portable Instruments
- Data Acquisition System Interface

Device Selection Table

Part Number	Package	Temperature Range
TC520ACOE	16-Pin SOIC (Wide)	0°C to +70°C
TC520ACPD	14-Pin PDIP	0°C to +70°C

Package Type

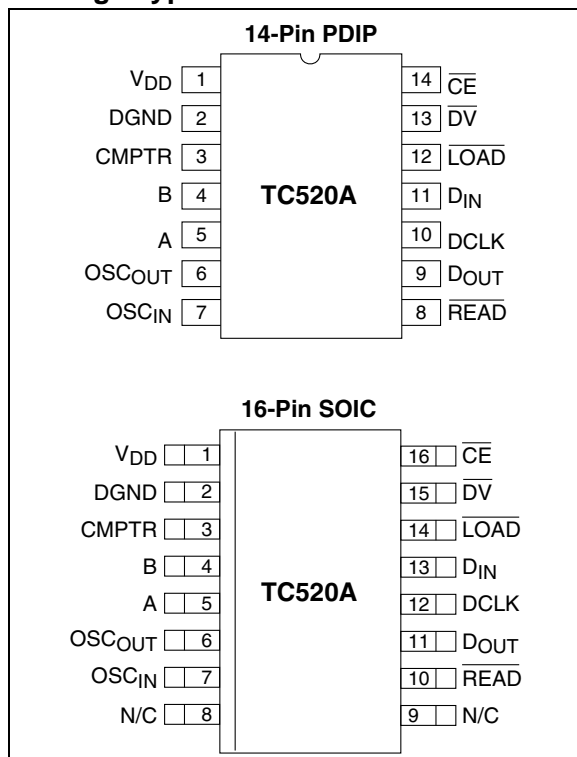

General Description

The TC520A serial interface adapter provides logic control for Microchip's TC500/TC500A/TC510/TC514 family of dual slope, integrating A/D converters. It directly manages TC500 converter phase control signals A, B and CMPTR, thereby reducing host processor task loading and software complexity. Communication with the TC520A is accomplished over a 3 wire serial port. Key converter operating parameters are programmable for complete user flexibility. Data conversion is initiated when the \overline{CE} input is brought low. The converted data (plus overrange and polarity bits) are held in an 18-bit shift register until read by the processor or until the next conversion is completed. Data may be clocked out of the TC520A at any time, and at any rate, the user prefers. A Data Valid (\overline{DV}) output is driven active at the start of each conversion cycle, indicating the 18-bit shift register update has just been completed. This signal may be polled by the processor or can be used as data ready interrupt. The TC520A timebase can be derived from an external frequency source of up to 6MHz or can operate from its own external crystal. It requires a single 5V logic supply and dissipates less than 7.5mΩ.

TC520A

Functional Block Diagram

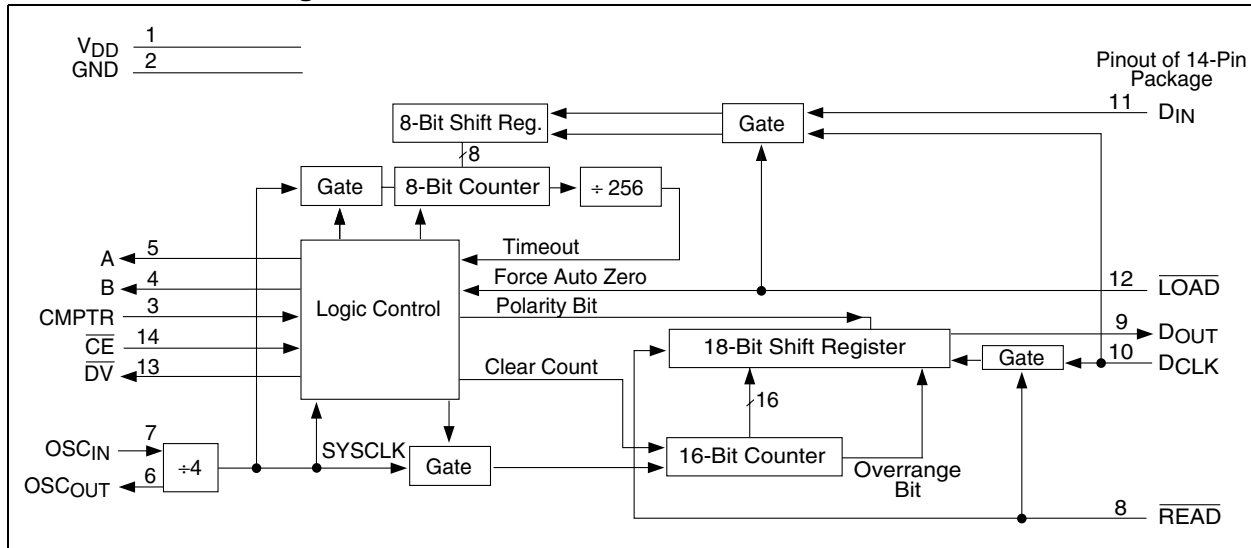

1.0 ELECTRICAL CHARACTERISTICS

Absolute Maximum Ratings*

DC Supply Voltage (V_{DD}) +6.0V
Input Voltage (All Inputs V_{IN}): - 0.3V to ($V_{DD} + 0.3V$)
Operating Temperature Range (T_A) 0°C to 70°C
Storage Temperature Range -65°C to +150°C

*Stresses above those listed under "Absolute Maximum Ratings" may cause permanent damage to the device. These are stress ratings only and functional operation of the device at these or any other conditions above those indicated in the operation sections of the specifications is not implied. Exposure to Absolute Maximum Rating conditions for extended periods may affect device reliability.

TC520A ELECTRICAL SPECIFICATIONS

Electrical Characteristics: $V_{DD} = 5V$, $F_{OSC} = 1MHz$, $T_A = +25^\circ C$, unless otherwise specified.						
Symbol	Parameters	Min	Typ	Max	Unit	Test Conditions
Supply						
V_{DD}	Operating Voltage Range	4.5	5	5.5	V	
I_{DD}	Supply Current	—	0.8	1.5	mA	
Input Characteristics						
V_{IL}	Low Input Voltage	—	—	0.8	V	
V_{IH}	High Input Voltage	2.0	—	—	V	
I_{IL}	Input Leakage Current	—	—	10	μA	
I_{PD}	Pull-down Current (\overline{CE})	—	5	—	μA	
I_{PU}	Pull-up Current (\overline{READ} , \overline{LOAD})	—	5	—	μA	
Output Characteristics ($I_{OUT} = 250 \mu A$, $V_{DD} = 5V$)						
V_{OL}	Low Output Voltage	—	0.2	0.3	V	
V_{OH}	High Output Voltage	3.5	4.3	—	V	
T_R, T_F	$C_L = 10pF$, Rise/Fall Times	—	—	250	nsec	
Oscillator (OSC_{IN}, OSC_{OUT})						
F_{XTL}	Crystal Frequency	—	1.0	4.0	MHz	
F_{OSC}	External Frequency (OSC_{IN})	—	—	6.0	MHz	
Timing Characteristics						
T_{RD}	\overline{READ} Delay Time	250	—	—	nsec	
T_{RS}	Data Read Setup Time	1	—	—	μsec	
T_{DRS}	D_{CLK} to D_{OUT} Delay	450	—	—	nsec	
T_{LS}	\overline{LOAD} Setup Time	1	—	—	μsec	
T_{DLS}	Data Load Setup Time	50	—	—	nsec	
T_{PWL}	D_{CLK} Pulse Width Low Time	150	—	—	nsec	
T_{PWH}	D_{CLK} Pulse Width High Time	150	—	—	nsec	
T_{LDL}	Load Default Low Time	250	—	—	nsec	
T_{LDS}	Load Default Setup Time	250	—	—	nsec	
Parameter						
T_{IZ}	Integrator ZERO Time	—	0.5	—	msec	
T_{AZI}	Auto zero (RESET) Time at Power-Up	—	100	—	msec	

TC520A

2.0 PIN DESCRIPTIONS

The descriptions of the pins are listed in Table 2-1

TABLE 2-1: PIN FUNCTION TABLE

Pin Number 14-Pin PDIP	Pin Number 16-Pin SOIC	Symbol	Description
1	1	V _{DD}	Input. +5V ±10% power supply input with respect to DGND.
2	2	DGND	Input. Digital Ground.
3	3	CMPTR	Input, active high or low (depending on polarity of the voltage input to A/D converter). This pin connects directly to the zero crossing comparator output (CMPTR) of the TC5XX A/D converter. A high-to-low state change on this pin causes the TC520A to terminate the de-integrate phase of conversion.
4	4	B	Output, active high. The A and B outputs of the TC520A connect directly to the A and B inputs of the TC5XX A/D converter connected to the TC520A. The binary code on A, B determines the conversion phase of the TC5XX A/D converter: (A, B) = 01 places the TC5XX A/D converter into the Auto Zero phase; (A, B) = 10 for Integrate phase (INT); (A, B) = 11 for De-integrate phase (DINI) and (A, B) = 00 for Integrator Zero phase (IZ). Please see the TC500/TC500A/TC510/TC514 family data sheets for a complete description of these phases of operation.
5	5	A	Output, active high. See pin 4 description above.
6	6	OSC _{OUT}	Input. This pin connects to one side of an AT-cut crystal having a effective series resistance of 100Ω (typ.) and a parallel capacitance of 20pF (typ.). If an external frequency source is used to clock the TC520A, this pin must be left floating.
7	7	OSC _{IN}	Input. This pin connects to the other side of the crystal described in pin 6 above. The TC520A may also be clocked from an external frequency source connected to this pin. The external frequency source must be a pulse train having a duty cycle of 30% (minimum); rise and fall times of 15nsec and a min/max amplitude of 0 to V _{IH} . If an external frequency source is used, pin 6 must be left floating. A maximum operating frequency of 4MHz (crystal) or 6MHz (external clock source) is permitted.
	8	N/C	No connection on 16 pin package version.
	9	N/C	No connection on 16 pin package version.
8	10	READ	Input, active low, level and negative edge triggered. A high-to-low transition on $\overline{\text{READ}}$ loads serial port output shift register with the most recent converted data. Data is loaded such that the first bit transmitted from the TC520A to the processor is the OVERRANGE bit (OVR), followed by the POLARITY bit (POL) (high = input positive; low = input negative). This is followed by a 16-bit data word (MSB first). OVR is available at the D _{OUT} as soon as $\overline{\text{READ}}$ is brought low. This bit may be used as the 17th data bit, if so desired. The D _{OUT} pin of the serial port is enabled only when $\overline{\text{READ}}$ is held low. Otherwise, D _{OUT} remains in a high impedance state. A serial port read access cycle is terminated at any time by bringing $\overline{\text{READ}}$ high.
9	11	D _{OUT}	Output, logic level. Serial port output pin. This pin is enabled only when $\overline{\text{READ}}$ is low (see $\overline{\text{READ}}$ pin description).
10	12	D _{CLK}	Input, positive and negative edge triggered. Serial port clock. With $\overline{\text{READ}}$ low, serial data is clocked into the TC520A at each low-to-high transition of D _{CLK} , and clocked out of the TC520A on each high-to-low transition of D _{CLK} . A maximum serial port D _{CLK} frequency of 3MHz is permitted.
11	13	D _{IN}	Input, logic level. Serial port input pin. The TC5XX A/D converter integration time (T _{INT}) and Auto Zero time (TAZ) values are determined by the LOAD VALUE byte clocked into this pin. This initialization must take place at power up and can be rewritten (or modified and rewritten) at any time. The LOAD VALUE is clocked into D _{IN} MSB first.

TABLE 2-1: PIN FUNCTION TABLE (CONTINUED)

Pin Number 14-Pin PDIP	Pin Number 16-Pin SOIC	Symbol	Description
12	14	$\overline{\text{LOAD}}$	Input, active low; level and edge triggered. The LOAD VALUE is clocked into the 8-bit shift register on board the TC520A while $\overline{\text{LOAD}}$ is held low. The LOAD VALUE is then transferred into the TC520A internal timebase counter (and becomes effective) when $\overline{\text{LOAD}}$ is returned high. If so desired, $\overline{\text{LOAD}}$ can be momentarily pulsed low, eliminating the need to clock a LOAD VALUE into D_{IN} . In this case, the current state of D_{IN} is clocked into the TC520A timebase counter selecting either a count of 65536 ($D_{\text{IN}} = \text{High}$), or count of 32768, ($D_{\text{IN}} = \text{Low}$).
13	15	$\overline{\text{DV}}$	Output, active low. $\overline{\text{DV}}$ is brought low any time the TC520A is in the AZ phase of conversion. This occurs when, either the TC520A initiates a normal AZ phase by setting A, B, equal to 01, or when $\overline{\text{CE}}$ is pulled high, which overrides the normal A, B sequencing and forces an AZ state. $\overline{\text{DV}}$ is returned high when the TC520A exits AZ.
14	16	$\overline{\text{CE}}$	Input, active low, level triggered. Conversion will be continuously performed as long as $\overline{\text{CE}}$ remains low. Pulling $\overline{\text{CE}}$ high causes the conversion process to be halted and forces the TC520A into the AZ mode for as long as $\overline{\text{CE}}$ remains high. $\overline{\text{CE}}$ should be taken high whenever it is necessary to momentarily suspend conversion (for example: to change the address lines of an input multiplexer). $\overline{\text{CE}}$ should be pulled high only when the TC520A enters an AZ phase (i.e. when $\overline{\text{DV}}$ is low). This is necessary to avoid excessively long integrator discharge times, which could result in erroneous conversion. This pin should be grounded if unused. It should be left floating if a 0.01 μF RESET capacitor is connected to it (see Section 4.0, Typical Applications).

3.0 DETAILED DESCRIPTION

3.1 TC520A Timing

The TC520A consists of a serial port and state machine. The state machine provides control timing to the TC5xx A/D converter connected to the TC520A as well as providing sequential timing for TC520A internal operation. All timing is derived from the frequency source at OSC_{IN} and OSC_{OUT} . This frequency source can be either an externally provided clock signal or external crystal. If an external clock is used, it must be connected to the OSC_{IN} pin and OSC_{OUT} must remain floating. If a crystal is used, it must be connected between the OSC_{IN} and OSC_{OUT} and be physically located as close to the OSC_{IN} and OSC_{OUT} pins as possible. The incoming frequency is internally divided by 4 and the resulting clock (SYSCLK) controls all timing functions.

3.2 TC5XX A/D Converter Control Signals

The TC520A control outputs (A, B) and control input (CMPTR) connect directly to the corresponding pins of the TC5XX A/D converter. A conversion is consummated when A, B have been sequenced through the required 4 phases of conversion: Auto Zero (AZ), Integrate (INT), De-integrate (D_{INT}) and Integrator Zero (IZ) (see Figure 4-1). The Auto Zero phase compensates for offset errors in the TC5XX A/D converter. The Integrate phase connects the voltage to be converted to the TC5XX A/D converter input, resulting in an integrator output dv/dt directly proportional to the magnitude of the applied input voltage. Actual A/D conversion (counting) is initiated at the start of the D_{INT} phase and terminates when the integrator output crosses 0V. The integrator output is then forced to 0V during the IZ phase and the converter is ready for another cycle. Please see the TC500/TC500A/TC510/TC514 data sheet for a complete description of these phases.

The number of SYSCLK periods (counts) for the AZ and INT phases is determined by the LOAD VALUE. The LOAD VALUE is a single byte that must be loaded into the most significant byte of 16-bit counter on board the TC520A during initialization. The lower byte of this counter is pre-loaded to a value of 0FFH (256_{10}) and cannot be changed.

The LOAD VALUE (upper 8 bits of the counter) can be programmed over a range of 0FFH to 00H (corresponding to a range of $AZ = INT = 256$ counts to 65536 counts). (See Figure 3-2). The LOAD VALUE sets the number of counts for both the AZ and INT phases and directly affects resolution and speed of conversion. The greater the number of counts allowed for AZ and INT, the greater the A/D resolution (but the slower the conversion speed).

The time period required for the D_{INT} phase is a function of the amount of voltage stored on the integrator during the INT phase and the value of V_{REF} . The D_{INT} phase is initiated by the TC520A immediately after the INT phase and terminated when the TC5XX A/D converter changes the state of the CMPTR input of the TC520A, indicating a zero crossing. In general, the maximum number of counts chosen for D_{INT} is twice that of INT (with V_{REF} chosen at $V_{ININ(MAX)}/2$). Choosing these values guarantees a full count (maximum resolution) during D_{INT} when $V_{IN} = V_{IN(MAX)}$.

The IZ phase is initiated immediately following the D_{INT} phase and is maintained until the CMPTR input transitions high. This indicates the integrator is initialized and ready for another conversion cycle. This phase typically takes 2msec.

3.3 Serial Port Control Signals

Communication to and from the TC520A is accomplished over a 3 wire serial port. Data is clocked into D_{IN} on the rising edge of D_{CLK} and clocked out of D_{OUT} on the falling edge of D_{CLK} . READ must be low to read from the serial port and can be taken high at any time, which terminates the read cycle and releases D_{OUT} to a high impedance state. Conversion data is shifted to the processor from D_{OUT} in the following order: OVERRANGE (which can also be used as the 17th data bit), POLARITY, conversion data (MSB first).

4.0 TYPICAL APPLICATIONS

4.1 TC500 Series A/D Converter Component Selection

The TC500/TC500A/TC510/TC514 data sheet details the equations necessary to calculate values for integration resistor (R_{INT}) and capacitor (C_{INT}), auto zero (C_{AZ}) and reference capacitors (C_{REF}) and voltage reference (V_{REF}). All equations apply when using the TC520A, except Integration time (T_{INT}) and Auto zero time (T_{AZ}), which are functions of the SYSCLK period (timebase frequency and LOAD VALUE). Microchip offers a ready-to-use TC5XX A/D converter design tool. The TC500 Design Spreadsheet is an Excel-based spreadsheet that calculates values for all components as well as the TC520A LOAD VALUE. It also calculates overall converter performance such as noise rejection, converter speed, etc.

4.2 TC520A Initialization

Initialization of the TC520A consists of:

1. Power-On RESET of the TC500/TC520A (forcing the TC520A into an AZ phase).
2. Initializing the TC520A LOAD VALUE.

4.3 Power-On RESET

The TC520A powers up with A,B = 00 (IZ Phase), awaiting a high logic state on CMPTR, which must be initiated by forcing the TC520A into the AZ phase. This can be accomplished in one of two ways:

1. External hardware (processor or logic) can momentarily pull LOAD or CE low for a minimum of 100msec (T_{AZI}) or;
2. A .01 μ F RESET capacitor can be connected from CE to V_{CC} to generate a power-on pulse on CE.

4.4 LOAD VALUE Initialization

The LOAD VALUE is the preset value (high byte of the SYSCLK timing counter) which determines the number of counts allocated to the AZ and INT phases of conversion. This value can be calculated using either the TC520A spreadsheet within the TC500 Design Spreadsheet software or can be setup as shown in the following sections.

4.4.1 SELECT V_{REF} , T_{DEINT}

Choose the TC5XX A/D converter reference voltage (V_{REF}) to be half of the maximum A/D converter input voltage. For example, if $V_{IN(MAX)} = 2.5V$, choose $V_{REF} = 1.25V$. This forces the maximum de-integration time (T_{DEINT}) to be equal to twice the maximum integration time (T_{INT}), ensuring a full count (maximum resolution) during DINT.

4.4.2 CALCULATE T_{INT}

The TC520A counter length is 16-bits (65536), allowing the full 65536 counts for T_{DEINT} results in a maximum $T_{INT} = 65536/2$ or 32768.

4.4.3 SELECT SYSCLK FREQUENCY

SYSCLK frequency directly affects conversion time. The faster the SYSCLK, the faster the conversion time. The upper limit SYSCLK frequency is determined by the worst case delay of the TC500 comparator (which for the TC500 and TC500A is 3.2 μ sec). While a faster value for SYSCLK can be used, operation is optimized (error minimized) by choosing a SYSCLK period (1/SYSCLK frequency) that is greater than 3.2 μ sec. Choosing $T_{SYSCLK} = 4\mu$ sec makes the SYSCLK frequency equal to 250kHz. This makes the external crystal (or frequency source) equal to 1.0MHz, since $SYSCLK = \text{crystal frequency}/4$. Calculating integration time (in msec) using $T_{SYSCLK} = 4\mu$ sec, $T_{INT} = 4\mu$ sec \times 32768 = 131msec.

4.4.4 CALCULATE LOAD VALUE

Plug the T_{INT} and T_{SYSCLK} values into the equation and convert the resulting value to hexadecimal:

EQUATION 4-1:

$$\text{LOAD VALUE} = \frac{[(65536 - (T_{INT}/T_{SYSCLK}))]}{256}$$

In this example, $\text{LOAD VALUE} = 128_{(10)} = 10H$. Therefore, a LOAD VALUE of 10H is loaded into the TC520A. If the desired T_{INT} was 100msec instead of 131msec, the LOAD VALUE would be 9EH, and so on. The TC520A LOAD VALUE must be initialized on power-up, and can be re-initialized as often as desired thereafter. This is accomplished by bringing the LOAD input low while transmitting the appropriate LOAD VALUE to the TC520A as shown in Figure 4-1 and Figure 4-2.

4.4.5 POLLED VS. INTERRUPT OPERATION

The TC520A can be accessed at any time by the host processor. This makes operation in a polled environment especially easy since the most recently converted data is available to the processor as needed. The TC520A can also be used in an interrupt environment by connecting DV to the IRQ line of the processor. Since AZ is the first phase of a new conversion cycle, the most recently converted data will be available as soon as \overline{DV} goes low. If so desired, the interrupt service routine can also modify the LOAD VALUE during the $\overline{DV} = \text{low}$ interval.

TC520A

FIGURE 4-1: TC520A initialization & startup conversion timing relationships

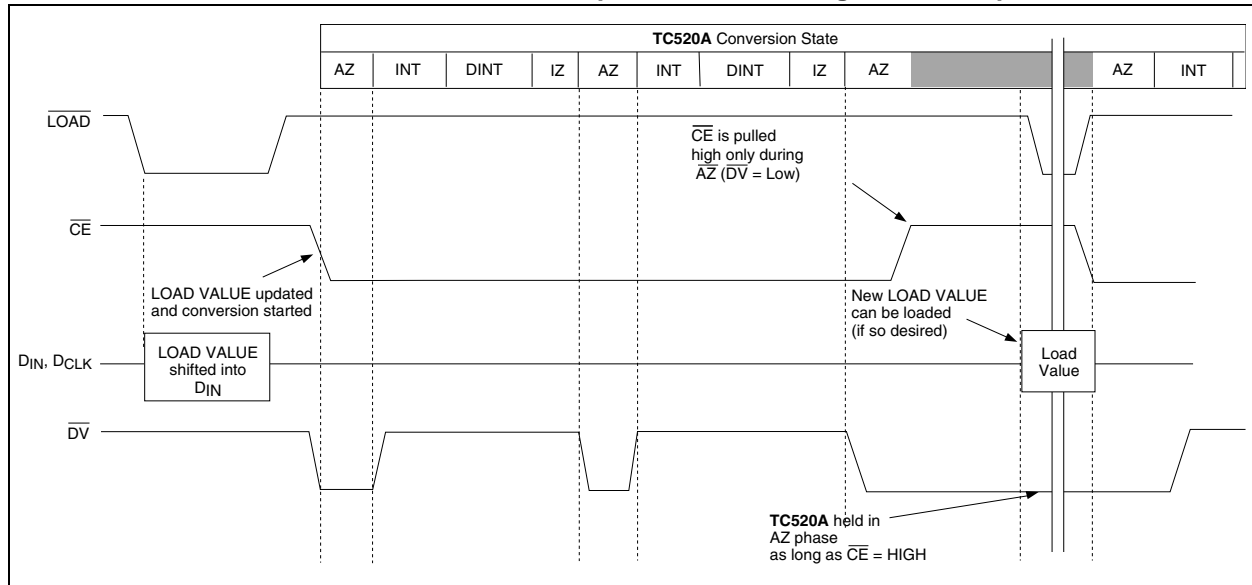
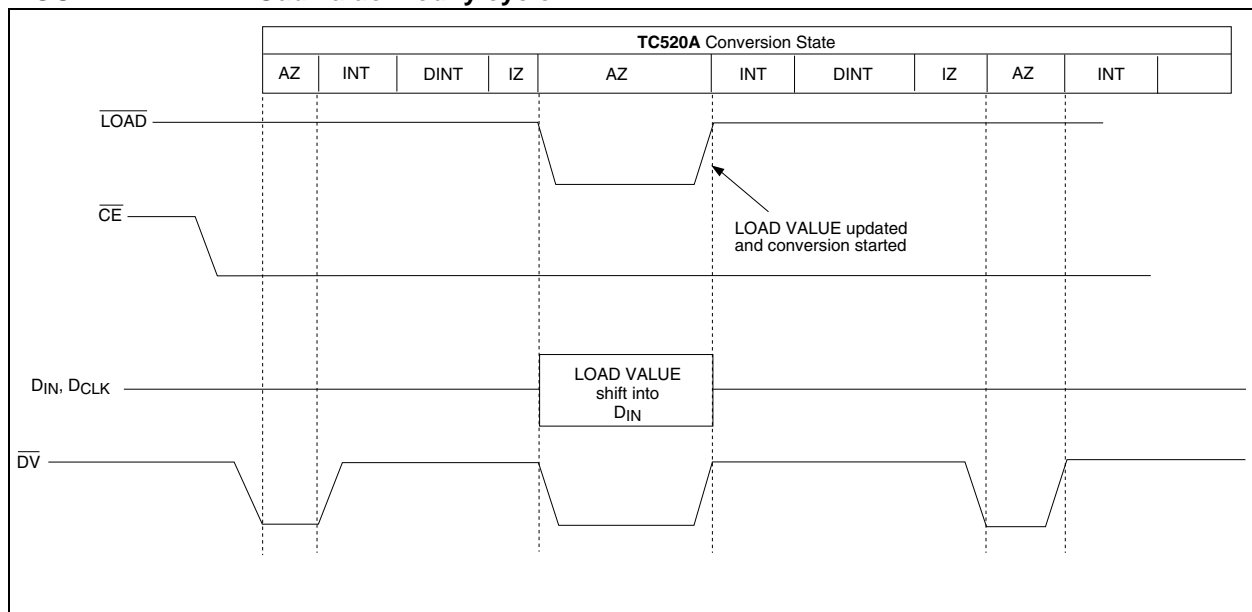

FIGURE 4-2: Load value modify cycle



4.4.6 OPTO-ISOLATED APPLICATIONS

The 3 wire serial port of the TC520A can be opto-isolated for applications requiring isolated data acquisition. The additional control lines ($\overline{\text{LOAD}}$, $\overline{\text{DV}}$, $\overline{\text{READ}}$) are normally not needed in such applications, but can also be brought across the isolation barrier with the addition of a second isolator.

FIGURE 4-3: Typical System Application

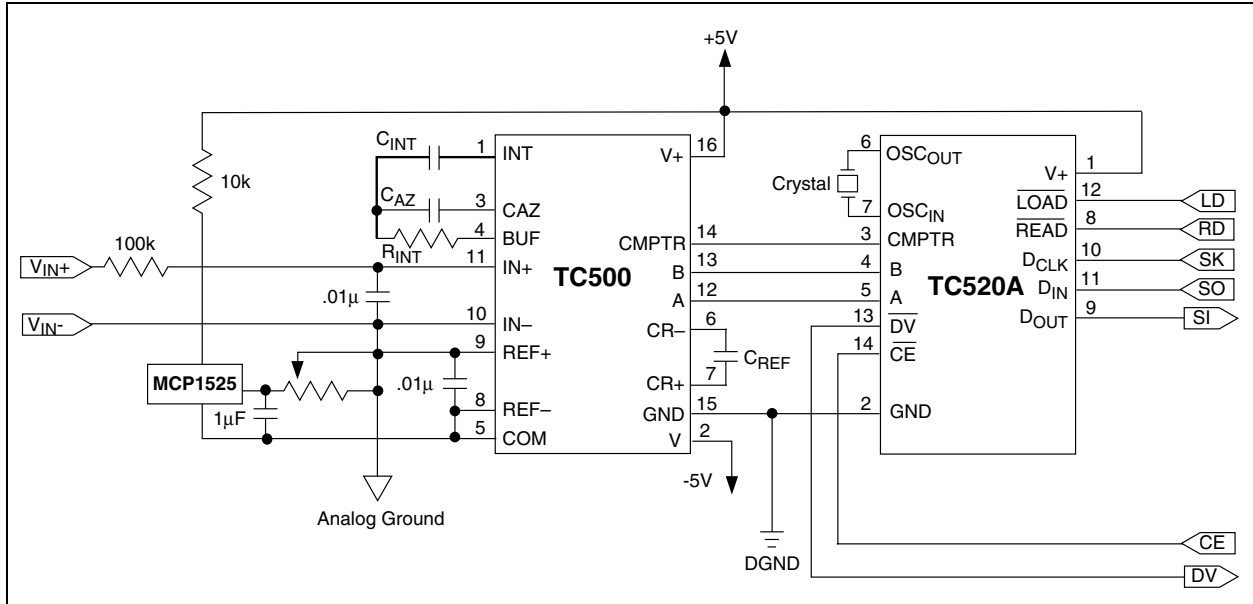
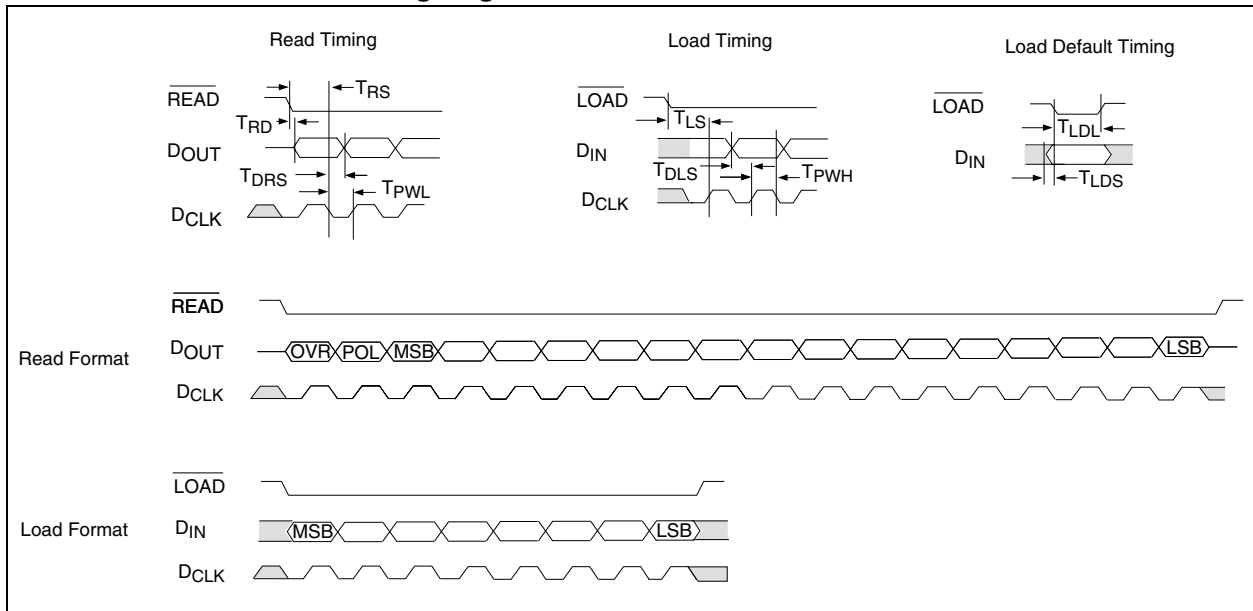

FIGURE 4-4: TC520A timing diagram



TC520A

5.0 PACKAGING INFORMATION

5.1 Package Marking Information

Package marking information not available at this time.

5.2 Taping Forms

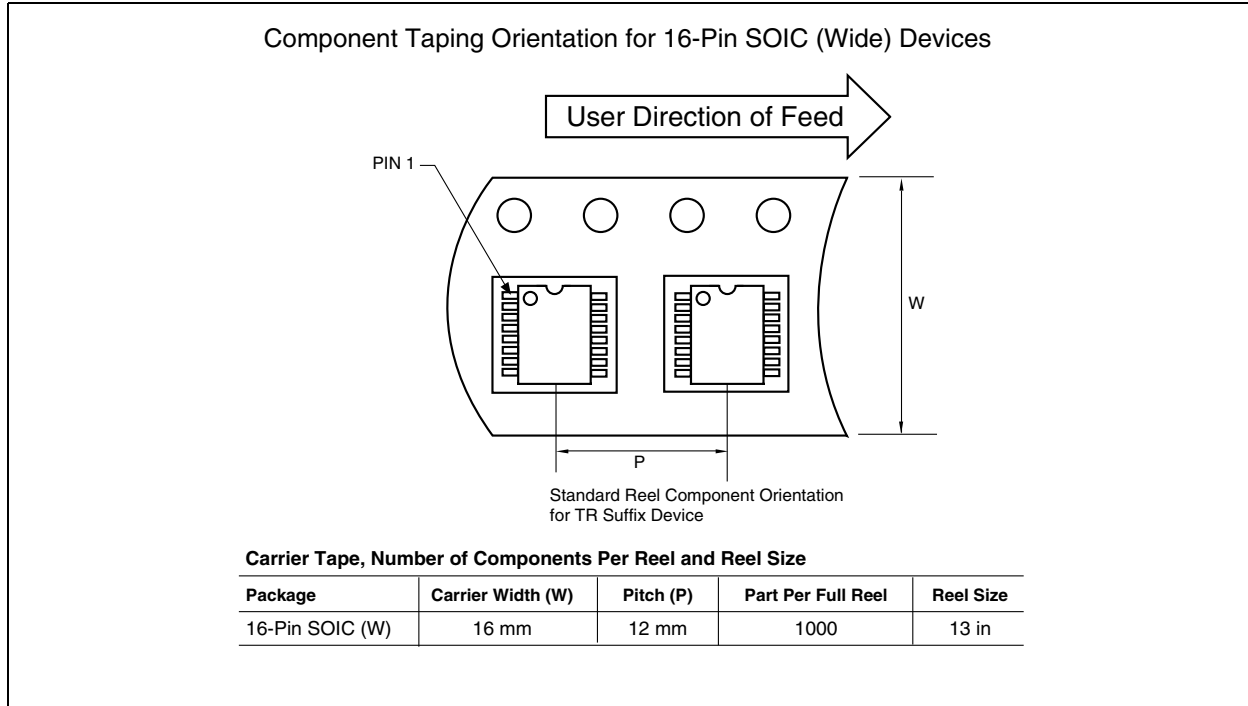

5.3 Package Dimensions

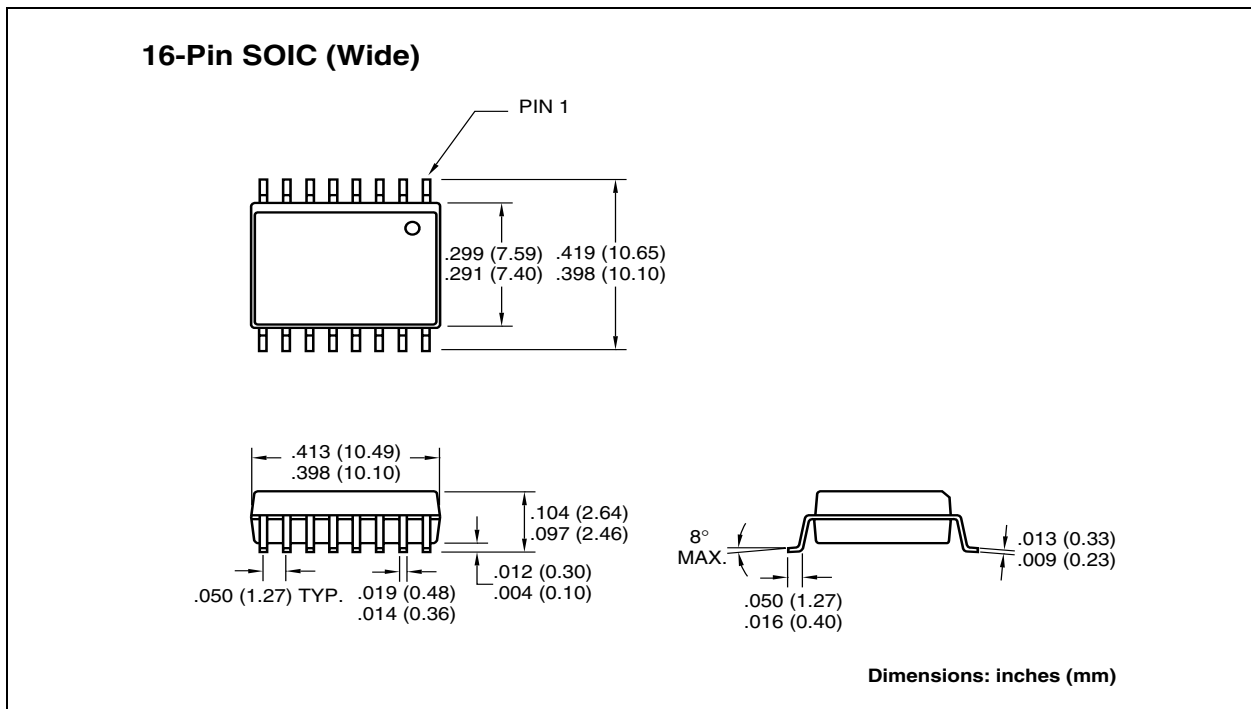
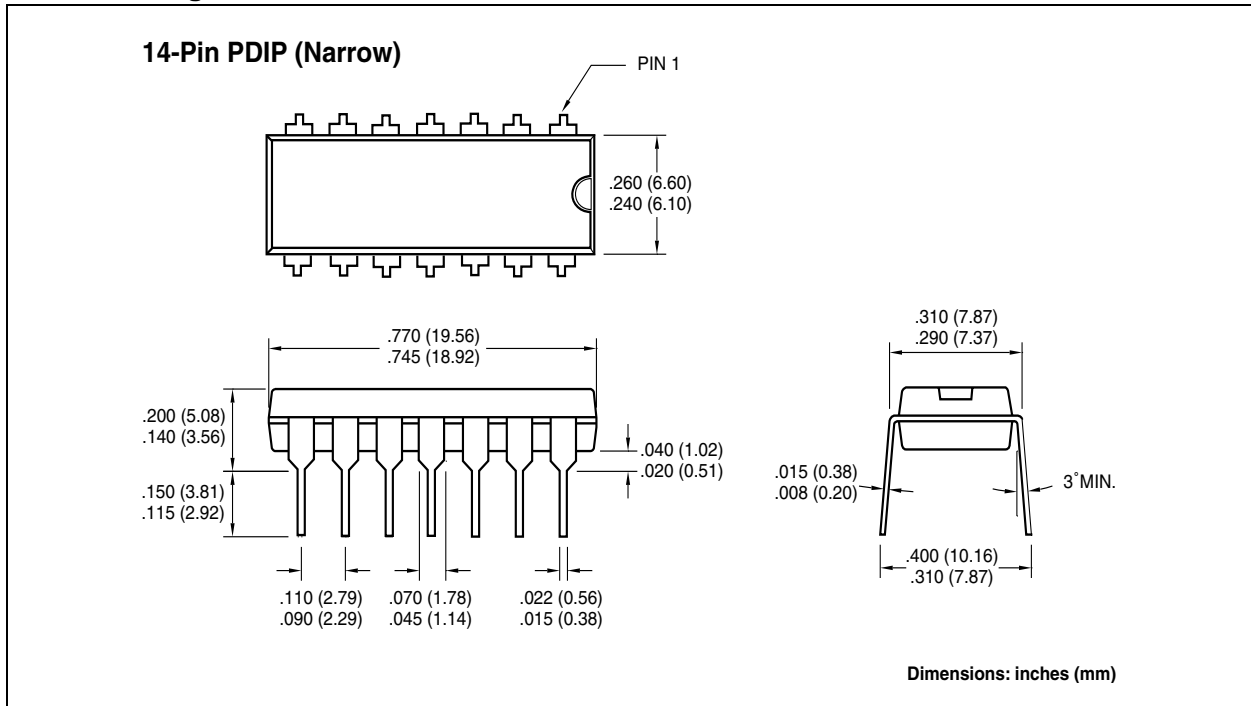

SALES AND SUPPORT

Data Sheets

Products supported by a preliminary Data Sheet may have an errata sheet describing minor operational differences and recommended workarounds. To determine if an errata sheet exists for a particular device, please contact one of the following:

1. Your local Microchip sales office
2. The Microchip Corporate Literature Center U.S. FAX: (480) 792-7277
3. The Microchip Worldwide Site (www.microchip.com)

Please specify which device, revision of silicon and Data Sheet (include Literature #) you are using.

New Customer Notification System

Register on our web site (www.microchip.com/cn) to receive the most current information on our products.

TC520A

NOTES:

Information contained in this publication regarding device applications and the like is intended through suggestion only and may be superseded by updates. It is your responsibility to ensure that your application meets with your specifications. No representation or warranty is given and no liability is assumed by Microchip Technology Incorporated with respect to the accuracy or use of such information, or infringement of patents or other intellectual property rights arising from such use or otherwise. Use of Microchip's products as critical components in life support systems is not authorized except with express written approval by Microchip. No licenses are conveyed, implicitly or otherwise, under any intellectual property rights.

Trademarks

The Microchip name and logo, the Microchip logo, FilterLab, KEELOQ, microID, MPLAB, PIC, PICmicro, PICMASTER, PICSTART, PRO MATE, SEEVAL and The Embedded Control Solutions Company are registered trademarks of Microchip Technology Incorporated in the U.S.A. and other countries.

dsPIC, ECONOMONITOR, FanSense, FlexROM, fuzzyLAB, In-Circuit Serial Programming, ICSP, ICEPIC, microPort, Migratable Memory, MPASM, MPLIB, MPLINK, MPSIM, MXDEV, PICC, PICDEM, PICDEM.net, rfPIC, Select Mode and Total Endurance are trademarks of Microchip Technology Incorporated in the U.S.A.

Serialized Quick Turn Programming (SQTP) is a service mark of Microchip Technology Incorporated in the U.S.A.

All other trademarks mentioned herein are property of their respective companies.

© 2002, Microchip Technology Incorporated, Printed in the U.S.A., All Rights Reserved.

 Printed on recycled paper.



Microchip received QS-9000 quality system certification for its worldwide headquarters, design and wafer fabrication facilities in Chandler and Tempe, Arizona in July 1999 and Mountain View, California in March 2002. The Company's quality system processes and procedures are QS-9000 compliant for its PICmicro® 8-bit MCUs, KEELOQ® code hopping devices, Serial EEPROMs, microperipherals, non-volatile memory and analog products. In addition, Microchip's quality system for the design and manufacture of development systems is ISO 9001 certified.



MICROCHIP

WORLDWIDE SALES AND SERVICE

AMERICAS

Corporate Office

2355 West Chandler Blvd.
Chandler, AZ 85224-6199
Tel: 480-792-7200 Fax: 480-792-7277
Technical Support: 480-792-7627
Web Address: <http://www.microchip.com>

Rocky Mountain

2355 West Chandler Blvd.
Chandler, AZ 85224-6199
Tel: 480-792-7966 Fax: 480-792-7456

Atlanta

500 Sugar Mill Road, Suite 200B
Atlanta, GA 30350
Tel: 770-640-0034 Fax: 770-640-0307

Boston

2 Lan Drive, Suite 120
Westford, MA 01886
Tel: 978-692-3848 Fax: 978-692-3821

Chicago

333 Pierce Road, Suite 180
Itasca, IL 60143
Tel: 630-285-0071 Fax: 630-285-0075

Dallas

4570 Westgrove Drive, Suite 160
Addison, TX 75001
Tel: 972-818-7423 Fax: 972-818-2924

Detroit

Tri-Atria Office Building
32255 Northwestern Highway, Suite 190
Farmington Hills, MI 48334
Tel: 248-538-2250 Fax: 248-538-2260

Kokomo

2767 S. Albright Road
Kokomo, Indiana 46902
Tel: 765-864-8360 Fax: 765-864-8387

Los Angeles

18201 Von Karman, Suite 1090
Irvine, CA 92612
Tel: 949-263-1888 Fax: 949-263-1338

New York

150 Motor Parkway, Suite 202
Hauppauge, NY 11788
Tel: 631-273-5305 Fax: 631-273-5335

San Jose

Microchip Technology Inc.
2107 North First Street, Suite 590
San Jose, CA 95131
Tel: 408-436-7950 Fax: 408-436-7955

Toronto

6285 Northam Drive, Suite 108
Mississauga, Ontario L4V 1X5, Canada
Tel: 905-673-0699 Fax: 905-673-6509

ASIA/PACIFIC

Australia

Microchip Technology Australia Pty Ltd
Suite 22, 41 Rawson Street
Epping 2121, NSW
Australia
Tel: 61-2-9868-6733 Fax: 61-2-9868-6755

China - Beijing

Microchip Technology Consulting (Shanghai)
Co., Ltd., Beijing Liaison Office
Unit 915
Bei Hai Wan Tai Bldg.
No. 6 Chaoyangmen Beidajie
Beijing, 100027, No. China
Tel: 86-10-85282100 Fax: 86-10-85282104

China - Chengdu

Microchip Technology Consulting (Shanghai)
Co., Ltd., Chengdu Liaison Office
Rm. 2401, 24th Floor,
Ming Xing Financial Tower
No. 88 TIDU Street
Chengdu 610016, China
Tel: 86-28-86766200 Fax: 86-28-86766599

China - Fuzhou

Microchip Technology Consulting (Shanghai)
Co., Ltd., Fuzhou Liaison Office
Unit 28F, World Trade Plaza
No. 71 Wusi Road
Fuzhou 350001, China
Tel: 86-591-7503506 Fax: 86-591-7503521

China - Shanghai

Microchip Technology Consulting (Shanghai)
Co., Ltd.
Room 701, Bldg. B
Far East International Plaza
No. 317 Xian Xia Road
Shanghai, 200051
Tel: 86-21-6275-5700 Fax: 86-21-6275-5060

China - Shenzhen

Microchip Technology Consulting (Shanghai)
Co., Ltd., Shenzhen Liaison Office
Rm. 1315, 13/F, Shenzhen Kerry Centre,
Renminnan Lu
Shenzhen 518001, China
Tel: 86-755-2350361 Fax: 86-755-2366086

China - Hong Kong SAR

Microchip Technology Hongkong Ltd.
Unit 901-6, Tower 2, Metroplaza
223 Hing Fong Road
Kwai Fong, N.T., Hong Kong
Tel: 852-2401-1200 Fax: 852-2401-3431

India

Microchip Technology Inc.
India Liaison Office
Divyasree Chambers
1 Floor, Wing A (A3/A4)
No. 11, O'Shaugnessey Road
Bangalore, 560 025, India
Tel: 91-80-2290061 Fax: 91-80-2290062

Japan

Microchip Technology Japan K.K.
Benex S-1 6F
3-18-20, Shinyokohama
Kohoku-Ku, Yokohama-shi
Kanagawa, 222-0033, Japan
Tel: 81-45-471-6166 Fax: 81-45-471-6122

Korea

Microchip Technology Korea
168-1, Youngbo Bldg. 3 Floor
Samsung-Dong, Kangnam-Ku
Seoul, Korea 135-882
Tel: 82-2-554-7200 Fax: 82-2-558-5934

Singapore

Microchip Technology Singapore Pte Ltd.
200 Middle Road
#07-02 Prime Centre
Singapore, 188980
Tel: 65-6334-8870 Fax: 65-6334-8850

Taiwan

Microchip Technology Taiwan
11F-3, No. 207
Tung Hua North Road
Taipei, 105, Taiwan
Tel: 886-2-2717-7175 Fax: 886-2-2545-0139

EUROPE

Denmark

Microchip Technology Nordic ApS
Regus Business Centre
Lautrup høj 1-3
Ballerup DK-2750 Denmark
Tel: 45 4420 9895 Fax: 45 4420 9910

France

Microchip Technology SARL
Parc d'Activite du Moulin de Massy
43 Rue du Saule Trapu
Batiment A - 1er Etage
91300 Massy, France
Tel: 33-1-69-53-63-20 Fax: 33-1-69-30-90-79

Germany

Microchip Technology GmbH
Gustav-Heinemann Ring 125
D-81739 Munich, Germany
Tel: 49-89-627-144 0 Fax: 49-89-627-144-44

Italy

Microchip Technology SRL
Centro Direzionale Colleoni
Palazzo Taurus 1 V. Le Colleoni 1
20041 Agrate Brianza
Milan, Italy
Tel: 39-039-65791-1 Fax: 39-039-6899883

United Kingdom

Microchip Ltd.
505 Eskdale Road
Winnersh Triangle
Wokingham
Berkshire, England RG41 5TU
Tel: 44 118 921 5869 Fax: 44-118 921-5820

04/20/02

